

(1.) Only for information.

(2.) Corrosion protection:
DIN 50979 Fe//Zn8//Cn//T0, Salt spray test min 120 h.

SAP No.	Mould No.	Vertical stiffness Cz [N/mm] $\pm 20\%$	Vertical permitted constant load Fz [N]
4000013121	786231	235	1500

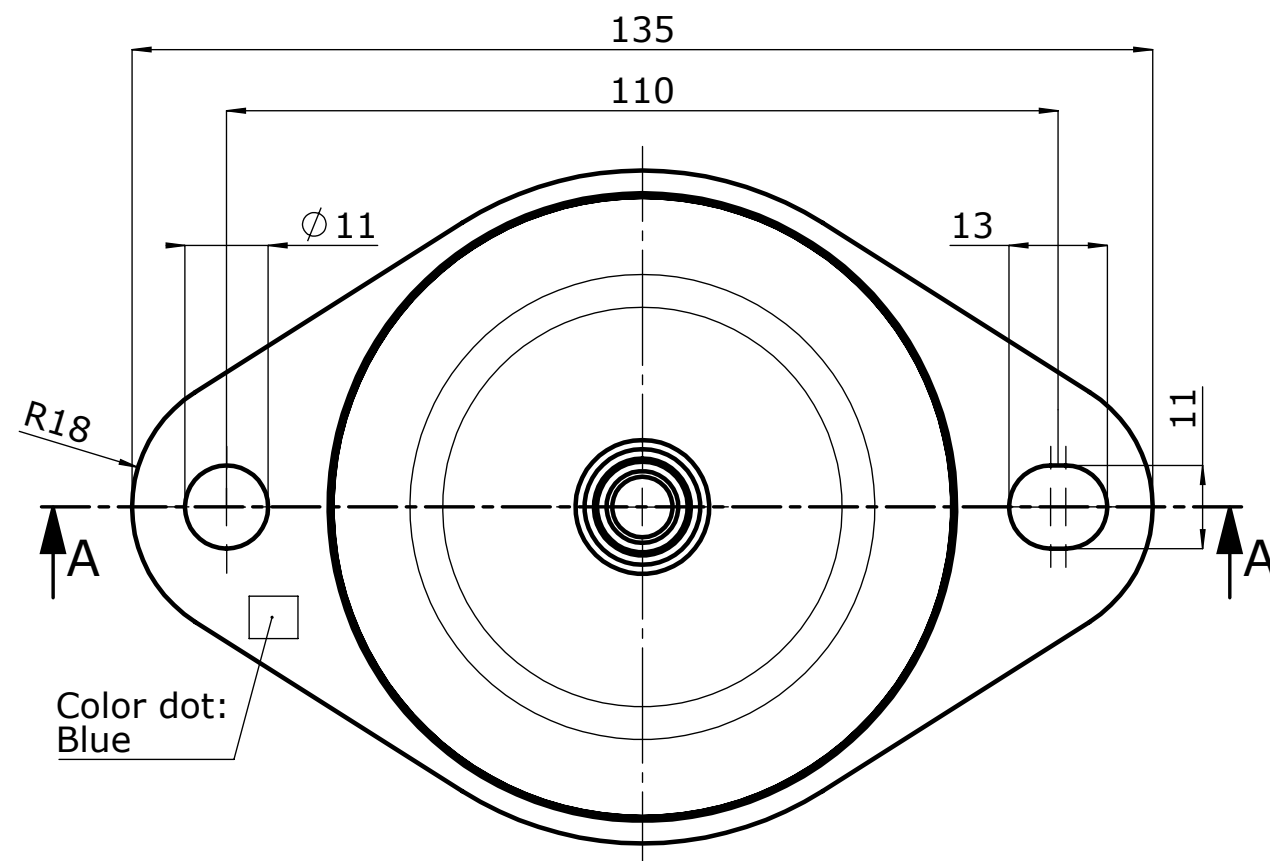
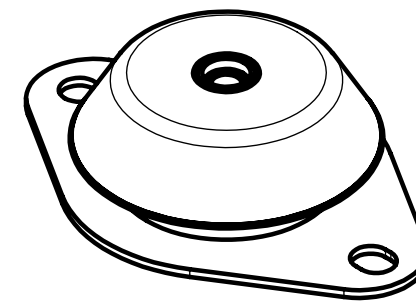

Only the English language version of the text is binding

Refer to protection notice ISO 16016	General tolerances	ISO 2768-mk ISO 3302-M3
Tolerancing principle SIZE ISO 14405 (E)	Lengths, radii, chamfers	
First angle projection ISO 5456-2	Angles	
Edges ISO 13715	Straightness, flatness	
Surfaces ISO 1302	Circularity, circular/total runout	
Surface calculated [mm ²]	Parallelism, perpendicularity	
Volume calculated [mm ³]	Symmetry	

Mould Number: 786231 **Code: 4000013121**

Scale:	Drawn		R&D Changshu SolidWorks
1:1	Checked		Format A3
	Approved		

Continental
ContiTech Vibration Control Changshu

Name:
**Machine mount
(Customer drawing)**

Replace for:
替换

Belongs to:
附属于

Drawing no.:
图号
CN15-0409